

## ***Man of Sin Revealed, Falling Away, That Day.***

2Thess. 2:3 Let no man deceive you by any means: for ***that day*** shall not come, except there come a ***falling away*** first, and that ***man of sin be revealed***, the son of perdition; 4 Who opposeth and exalteth himself above all that is called God, or that is worshipped; so that he as God sitteth in the temple of God, shewing himself that he is God. 5 Remember ye not, that, when I was yet with you, I told you these things? 6 And now ye know what withholdeth that he might be revealed in his time. 7 For the mystery of iniquity doth already work: only he who now letteth will let, until he be taken out of the way. 8 And then shall that Wicked be ***revealed***, whom the Lord shall consume with the spirit of his mouth, and shall destroy with the brightness of his coming:

Rev. 17:16 And the ten horns which thou sawest upon the beast, these shall hate the whore, and shall make her ***desolate*** and ***naked***, and shall eat her flesh, and ***burn her with fire***.

Note: Naked—Exposed—Revealed by the reformation. Desolate—by taking away its dominion. Here it is important to know what is the Wound and when WAS it healed. [WoundHealed.pdf](#)

All too well the people had learned the lessons of cruelty and torture which Rome had so diligently taught. A day of retribution at last had come. It was not now the disciples of Jesus that were thrust into dungeons and dragged to the stake. Long ago these had perished or been driven into exile. ***Unsparring Rome now felt the deadly power of those whom she had trained to delight in deeds of blood. "The example of persecution which the clergy of France had exhibited for so many ages, was now retorted upon them with signal vigor. The scaffolds ran red with the blood of the priests. The galleys and the prisons, once crowded with Huguenots, were now filled with their persecutors. Chained to the bench and toiling at the oar, the Roman Catholic clergy experienced all those woes which their church had so freely inflicted on the gentle heretics."*** (See Appendix.) {GC 283.2}

Note: France was the last of the 10 Horns/Toes in Western Europe to withdraw support from the Papacy. Rev. 11:13 “the tenth part of the city fell.” *Dan*; 7:7,8,20,24; *Rev. 13:4;17:3,7,12*. Also identified as a “***the great city*** was divided into three parts,” Paganism—how the ten horns/toes started out, Catholicism—what they became, and after the reformation fall to apostate Protestantism by denying the principle which they espoused, separation of church and state. <https://youtu.be/epDnsHf2CLM>

At the time when the Papacy, ***robbed of its strength, was forced to desist from persecution***, John beheld a new power coming up to echo the dragon's voice, and carry forward the same cruel

and blasphemous work. This power, the last that is to wage war against the church and the law of God, is represented by a beast with lamblike horns. The beasts preceding it had risen from the sea; but this came up out of the earth, representing the peaceful rise of the nation which it symbolized--the United States. {ST, February 8, 1910 par. 5} "1798"

## Bible Adventism

BY ELDER JAMES WHITE. Sermon Seven.  
THE JUDGEMENT.

Page 114-116

6. The termination of the 1260 years. From 538, 1260 years would extend to 1798. Did anything transpire that year to justify the belief that the dominion of the papacy ended at that time? It is a historical fact that, on Feb.10, 1798, Berthier, a French general, entered the city of Rome and took it. On the 15th of the same month, the pope was taken prisoner and shut up in the Vatican. The papal government, which had continued from the time of Justinian, was abolished, and a republican form of government given to Rome. The pope was carried captive to France, where he died in 1799. Thus, he that led into captivity went into captivity; he that killed with the sword was killed (subdued) with the sword. Rev.13:10. His dominion was taken away by war.

Verse 26: "But the Judgment shall sit, and they shall take away his dominion, to consume and to destroy it unto the end." See 2Thess.2:8: "Whom the Lord shall consume with the spirit of his mouth, and shall destroy with the brightness of his coming."

That the pope was restored, or a new one chosen is admitted. *But that he has power to depose kings and put the saints to death now, is denied. Before his dominion was wrested from him, he deposed kings at pleasure for centuries, and silenced heretics by the flame, the rack, the prison, and the sword. This he cannot do now, nor has he been able to do it since 1798. The papacy is compelled to tolerate Protestantism.* Hear the pope himself on that subject. Here is his letter, dated Sept., 1840, at Rome:—

"ENCYCLICAL LETTER OF OUR MOST HOLY LORD GREGORY XVI., by Divine Providence Pope, to all Patriarchs, Primate, Archbishops, and Bishops.

"Venerable Brethren,—Health and the Apostolic Benediction. You well know, Venerable Brothers, *how great are the calamities with which the Catholic church is beset on all sides in this most sorrowful age*, and how pitifully she is afflicted. . . . Indeed, are we not (oh, how shameful!) compelled to see the most crafty enemies of the truth, ranging far and wide with impunity; not only attacking religion with ridicule, the church with contumely, and Catholics with insults and slander, but even entering into cities and towns, establishing schools of error and impiety, publishing in print the poison of their doctrines, skillfully concealed under the deceitful veil of the natural sciences and new discoveries, and even penetrating into the cottages of the poor, traveling through rural districts, and insinuating themselves into familiar acquaintance with the lowest of the people, and with the farmers? Thus they leave no means unattempted, whether by corrupt Bibles in the language of the people, or pestiferous news- papers and other like

publications, or caviling conversation, or pretended charity, or, finally, by the gift of money, to allure ignorant people, and especially youth, into their nets, and induce them to desert the Catholic faith.

“We refer to facts, Venerable Brethren, which not only are known to you, but of which you are witnesses; even you, who, though you mourn, and, as your pastoral duty requires, are by no means silent, are yet compelled to tolerate in your dioceses these aforesaid propagators of heresy and infidelity. . . . Hence it is easy to conceive the state of anguish into which our soul is plunged day and night, as we, being charged with the superintendence of the whole fold of Jesus Christ, and the care of all the churches, must give account for his sheep to the Divine Prince of Pastors. And we have thought fit, Venerable Brethren, to recall to your minds by our present letter the causes of those troubles which are common to us and you, that you may more attentively consider how important it is to the church, that all holy priests should endeavor, with redoubled zeal, and with united labors, and with every kind of efforts, to repel the attacks of the raging foes of religion, to turn back their weapons, and to forewarn and fortify against the subtle blandishments which they often use. This, as you know, we have been careful to do at every opportunity; nor shall we cease to do it; as we also are not ignorant that you have always done it hitherto, and confidently trust that you will do hereafter with still more earnest zeal.”

“Given at Rome, at St. Mary the Greater, on the 18th of the Kalends of September, of the year 1840, the tenth of our pontificate.

“GREGORY XVI., Pope.”

## ***1260 years, The Investigative Judgement, Dominion taken away.***

This Has Happened.

Dan. 7:25 And he shall speak great words against the most High, and shall wear out the saints of the most High, and think to change times and laws: and they shall be given into his hand until a time and times and the dividing of time. 26 But the judgment shall sit, and **they shall take away his dominion**, to consume and to destroy it unto the end.

Rev. 13:5 And there was given unto him a mouth speaking great things and blasphemies; and power was given unto him to continue ***forty and two months***.

Rev. 17:17 For God hath put in their hearts to fulfil his will, and to agree, and ***give their kingdom unto the beast, until the words of God shall be fulfilled***.

Note: Rev. 17:17 “***until*** the words of God shall be ***fulfilled***.” Or “***until*** a time and times and the dividing of time.” Or “forty and two months,” then they would take their kingdoms back—taking away his dominion.

Rev. 11:3—thousand two hundred and threescore days, or 1260 years.

Crowns moved from 7 heads, papal head's the 7th to the  
10 Horns. Dominion taken away—Revealed.  
This Has Happened. Rev. 17:10-17. Dan. 7:8.

Rev. 12:3 And there appeared another wonder in heaven; and behold a great red dragon, having seven heads and ten horns, and *seven crowns* upon his heads.

Rev. 13:7 And it was *given unto him to make war with the saints, and to overcome them*: and power was given him over all kindreds, and tongues, and nations.

Rev. 13:1 And I stood upon the sand of the sea, and saw a beast rise up out of the sea, having seven heads and ten horns, and *upon his horns ten crowns*, and upon his heads the name of blasphemy.

Rev. 17:14 “*These*” (ten Horns) “*shall make war with the Lamb*, and the Lamb shall overcome them: for he is Lord of lords, and King of kings: and they that are with him are called, and chosen, and faithful.”

Note: Who exercises all the power? Authority, Who now has dominion? The [Image](#). [TheSevenHeads.pdf](#) Make war with the Lamb in the person of His saints—the good servant.

Matt. 24:48 But and if that evil servant shall say in his heart, My lord delayeth his coming; 49 And shall begin to *smite his fellow servants*, and to eat and drink with the drunken; 50 The lord of that servant shall come in a day when he looketh not for him, and in an hour that he is not aware of, 51 And shall cut him asunder, and appoint him his portion with the hypocrites: there shall be weeping and gnashing of teeth.

Note: see Rev. 13:15,16 below for how they smite their fellow servants.

Rev. 18:24 And in her” (The last 3rd of Babylon protestant evangelicals) “was found *the blood of prophets, and of saints*, and of all that were slain upon the earth.”

The fallen denominational churches comprise babylon. TM 61.3

The churches have become as described in the eighteenth chapter of Revelation.  
7BC 979.1

Note The Horns—Toes once united with the Papacy for its reign during 1260 years Rev. 17:13,17., but since that time do not unite! And they now persecute the Saints.

Earthly powers are shaken. We need not, and cannot, expect union among the nations of the earth. Our position in the image of Nebuchadnezzar is represented by the toes, in a divided state, and of a crumbling material, that will not hold together. Prophecy shows us that the great day of God is right upon us. It hasteth greatly. {1T 360.3}

My heart is often burdened because so many who might work are doing nothing. They are the sport of Satan's temptations. Every church member who has a knowledge of the truth is expected to work while the day lasts; for the night cometh, wherein no man can work. Erelong we shall understand what that night means. The Spirit of God is being grieved away from the earth. The nations are angry, with one another. Widespread preparations are being made for war. The night is at hand. Let the church arouse and go forth to do her appointed work. Every believer, educated or uneducated, can bear the message. {9T 26.3}

Rev. 11:18 And *the nations were angry*, and thy wrath is come, and the time of the dead, that they should be *judged*, and that thou shouldest give reward unto thy servants the prophets, and to the saints, and them that fear thy name, small and great; and shouldest destroy them which destroy the earth.

Note: Nations—Dan. 12:1; Thy wrath the 7 last plagues Rev. 16; The time of the Investigative Judgment Rev. 14:7; Give reward—Second Advent.

### *Falling Away.*

From Separating Church and State  
By Uniting them. [ProtestantPopery3.pdf](#)

Rev. 13:15 And he had power to give life *unto the image of the beast, that the image of the beast should both speak, and cause that as many as would not worship the image of the beast should be killed.* 16 And he causeth all, both small and great, rich and poor, free and bond, *to receive a mark* in their right hand, or in their foreheads:

Rev. 14:8 And there followed another angel, saying, *Babylon is fallen, is fallen, that great city, because she made all nations drink of the wine of the wrath of her fornication.*

Rev. 18:2 And he cried mightily with a strong voice, saying, *Babylon the great is fallen, is fallen*, and is become the habitation of devils, and the hold of every foul spirit, and a cage of every unclean and hateful bird. 3 *For all nations have drunk*

*of the wine of the wrath of her fornication*, and the kings of the earth have committed fornication with her, and the merchants of the earth are waxed rich through the abundance of her delicacies.

Note: Look at the lengths Republican Conservative Protestant Evangelicals are going to: legislating voting so restricted, passing laws to aid their unceasing effort for control, conspiracy theories, intimidation, threats, shootings. Will they take by force what they can't get by consent?

<https://youtu.be/23ZpMaOg-m8>

<https://youtu.be/Davcmbdh-6g>. <https://youtu.be/vsEK992eGS4>. <https://youtu.be/In3mMUzIHTQ>

<https://youtu.be/3SRzv1ZBTQE>. <https://youtu.be/ELUCFR23Q9w>

"I saw that the two-horned beast had a dragon's mouth, and that his power was in his head, and that the decree would go out of his mouth. *Then I saw the Mother of Harlots; that the mother was not the daughters, but separate and distinct from them. She has had her day, and it is past, and her daughters, the Protestant sects, were the next to come on the stage and act out the same mind that the mother had when she persecuted the saints.* I saw that as the mother has been *declining*, in power, the daughters had been *growing*, and soon *they will exercise* the power once exercised by the mother." {SpM 1.4}

### ***'That Day' is The Last Event in this Series.***

THE SECOND ADVENT Shall not come, Except  
there come a falling away First. 2Thess. 2:3

2Peter 3:10 But the day of the Lord will come as a thief in the night; in the which the heavens shall pass away with a great noise, and the elements shall melt with fervent heat, the earth also and the works that are therein shall be burned up.

Note: Neither do the events Under the 7 Churches or the 7 seals allow for a second universal new one world government for the papacy.



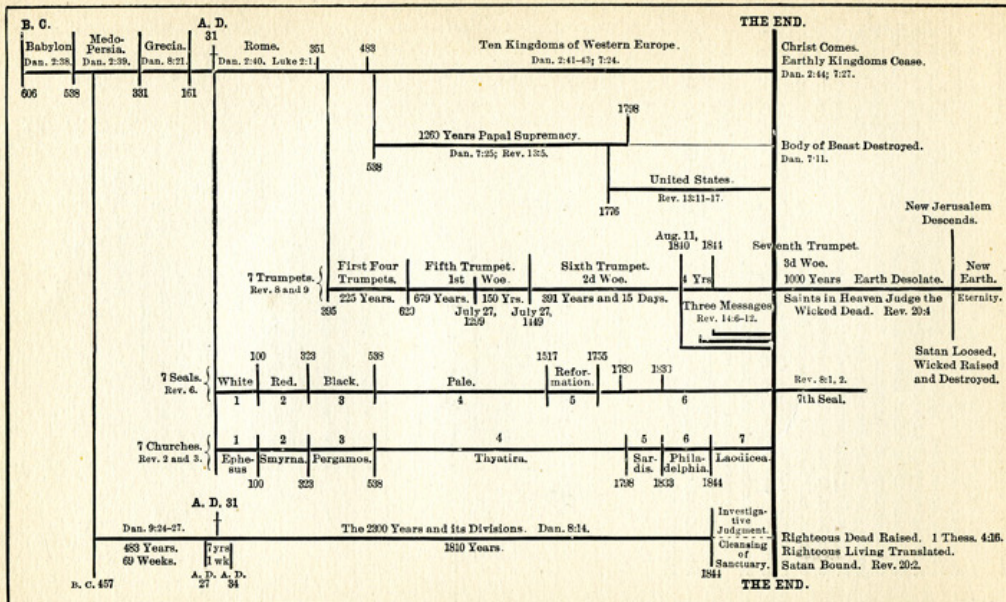

DIAGRAM OF EIGHT PROMINENT LINES OF PROPHECY.